

LABRİS A.Ş.

Malzeme Transfer Departmanı
Şirket İçi Personel Eğitimi-2023
Bant Ekleme Sistemleri



Konveyör Bandı Ekleme Sistemleri



- Mekanik Bant Ekleme Sistemleri
 - Ađır Tonajlı Bant Ekleme Sistemleri
 - Hafif Tonajlı Bant Ekleme Sistemleri
- Vulkanize Bant Ekleme Sistemleri



Ađır Tonajlı Konveyör Bandı Ekleme Sistemleri



-Perçinli Bant Ekleme Sistemleri
Mafsallı Sistemler
Mafsalsız Sistemler

-Zımbalı Bant Ekleme Sistemleri

-Vidalı Bant Ekleme Sistemleri
Mafsallı Sistemler
Mafsalsız Sistemler

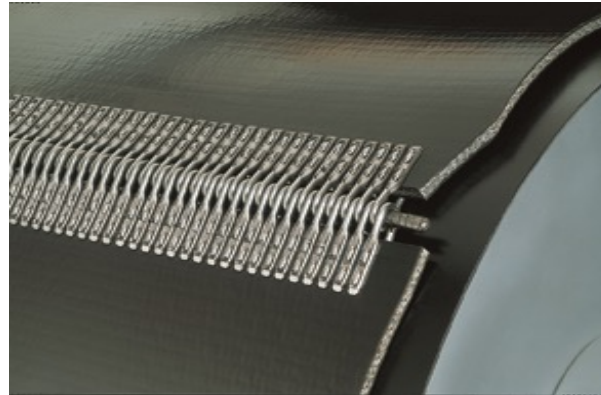

Perçinli Mafsallı Bant Ekleme Sistemleri

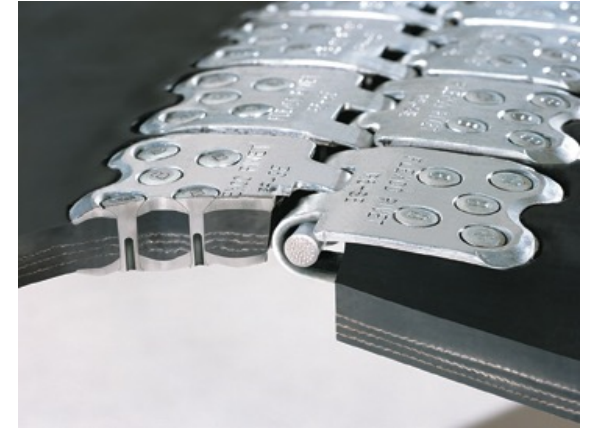
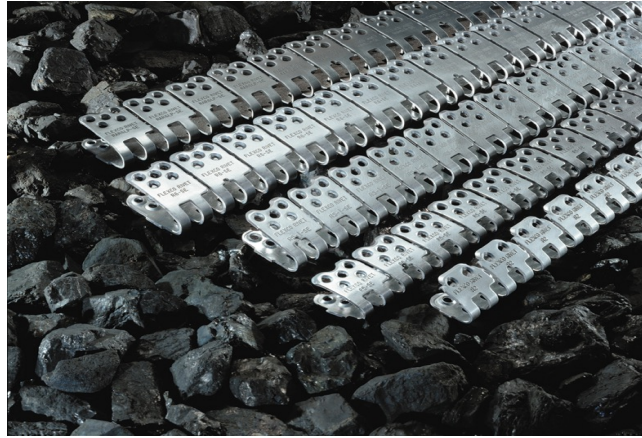

Perçinli Mafsalsız Bant Ekleme Sistemleri

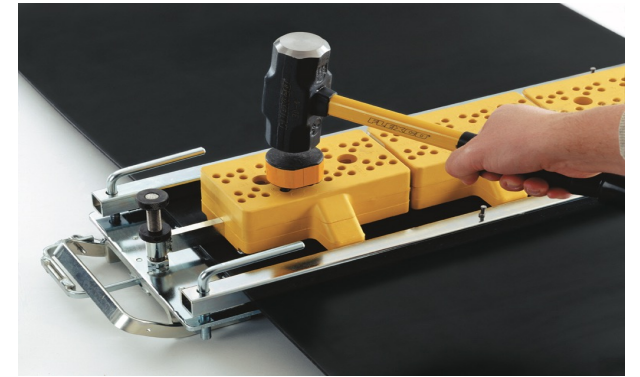
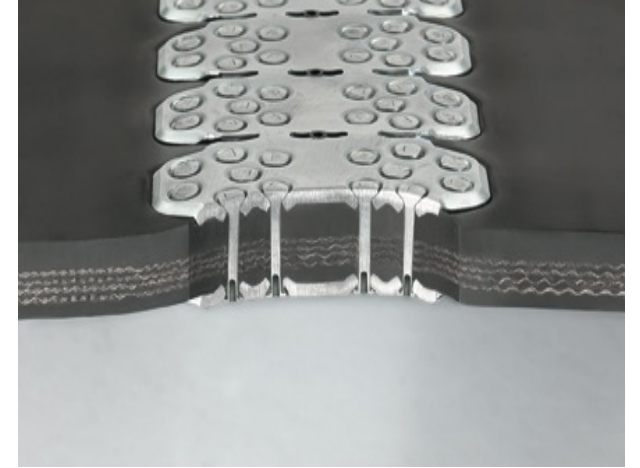

Mafsallı Vidalı Bant Ekleme Sistemleri

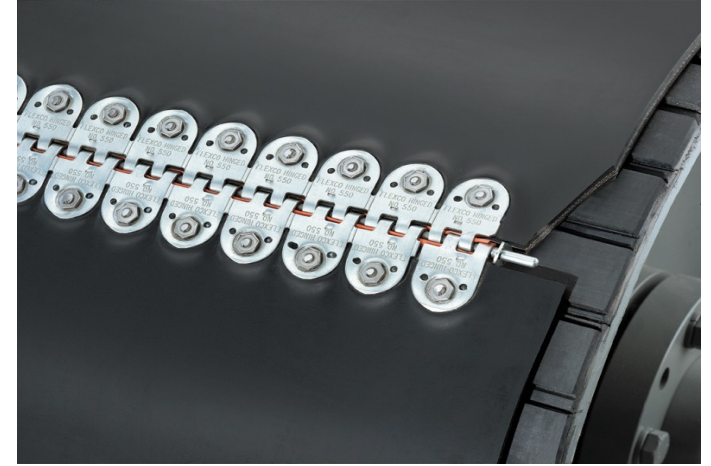

Zimbali Bant Ekleme Sistemleri



Mafsalsız Vidalı Bant Ekleme Sistemleri

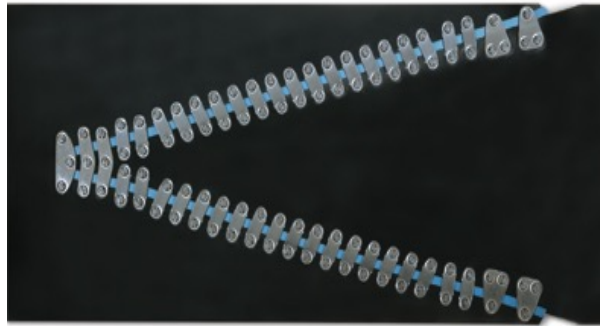
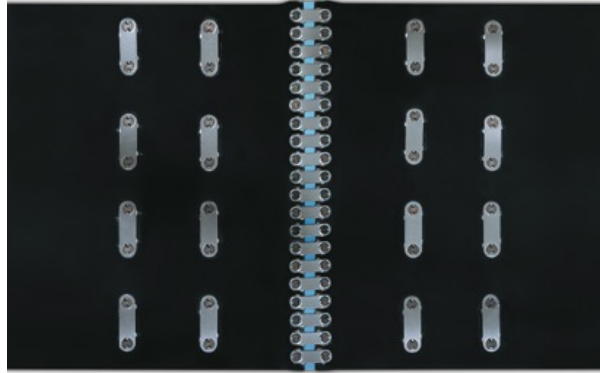
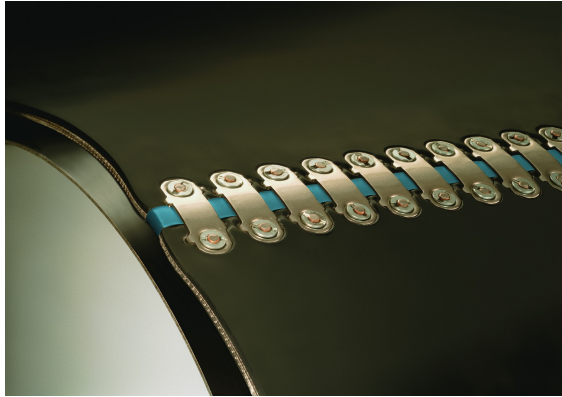

Çelik Kordlu Bant Ekleme Sistemleri



Kauçuk Bant Ekleme Sistemleri



Vulkanize Bant Ekleme Sistemleri

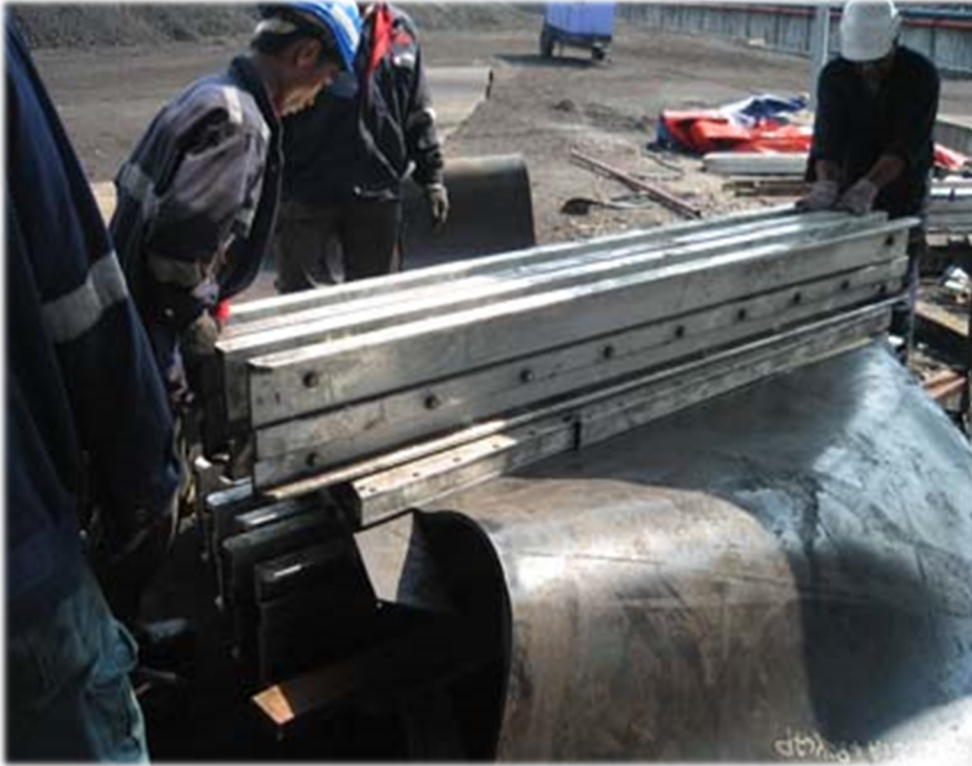

Hafif Tonajlı Konveyör Bandı Ekleme Sistemleri

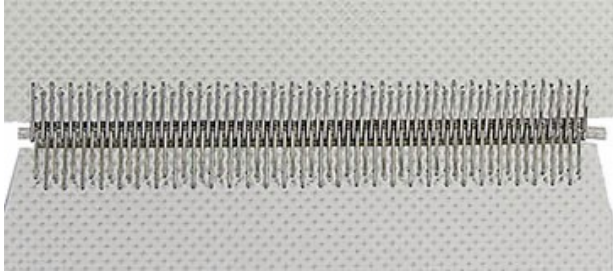

Hafif Tonajlı Konveyör Bandı Ekleme Sistemleri

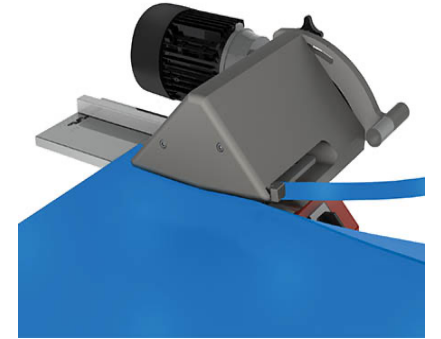

Hafif Tonajlı Konveyör Bandı Ekleme Sistemleri

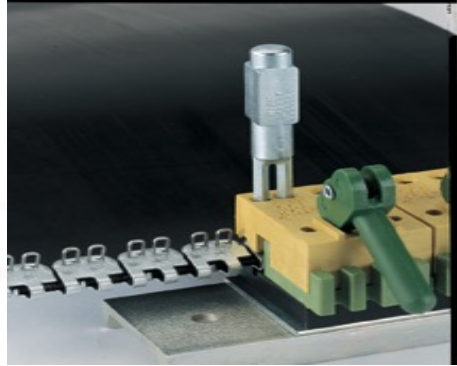
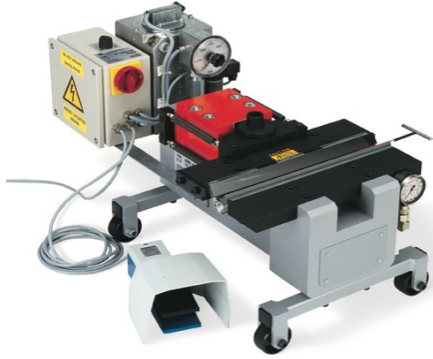

Dođru Ek Seęimi



Ařađıdaki 3 kalemin bilinmesi gerekir;

1-Bant gerilimi

2-Bant kalınlıđı

3-Sistem zerindeki U dnř yapılan yerdeki en kęk tambur apı

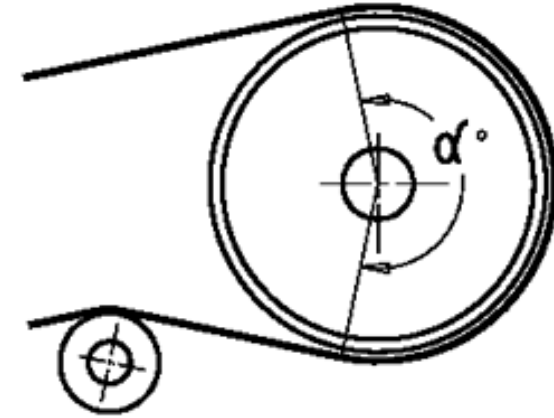

Mekanik Eklerin Avantajları



- Hızlı ve kolay montaj
- Düşük maliyet
- Bant kaybının az olması
- Kullanım emniyeti
- Kolay gözetim
- Sınırsız raf ömrü



Ađır Tonajlı iin Hedef Pazar Uygulamaları



- Kmr ve Metal Madenleri
- Kum ve tař ocakları
- Dkmhaneler
- Ađa iřleme tesisleri
- Demir elik Fabrikaları
- imento Fabrikaları
- Asfalt Tesisleri
- İnařaat ve Yol Ekipmanları, Makinaları
- Elavatrler, Konveyr ve Bant reticileri
- Gbre ve Tuz Tesisleri
- Endstriyel Hammadde Tesisleri
- Atık Tesisleri

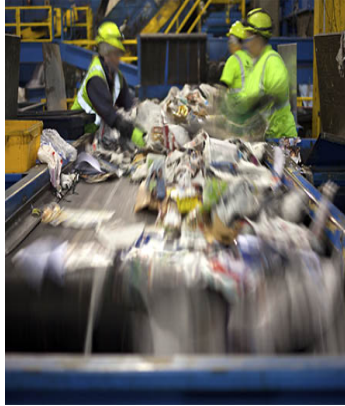

Hafif Tonajlı için Hedef Pazar Uygulamaları



- Gıda fabrikaları
- Çamaşır yıkama tesisleri
- Tarım Tesisleri
- Tahıl tesisleri
- Lojistik
- İmalat tesisleri
- Havaalanları
- Dağıtım Merkezleri
- Konveyör Üreticileri
- Bant Üreticileri,Satıcıları
- Filtre ve Filtre Bezi Üreticileri

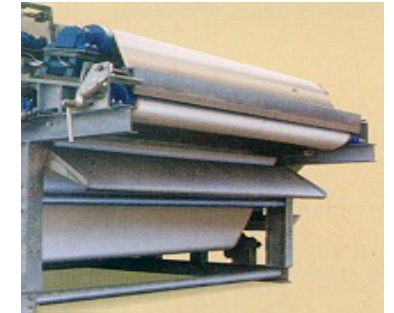
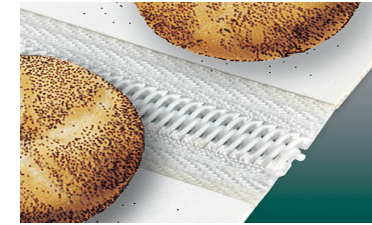
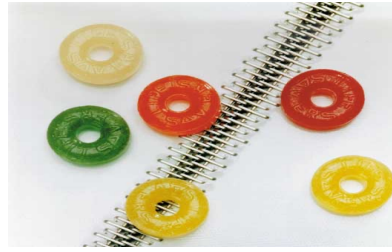

Ek Tipi Seçim Tablosu



RENKLER		FLEXCO BANT EKLEME SİSTEMLERİ SEÇİM TABLOSU																		
BOLT HINGED		RIVET SOLID PLATE		BOLT SOLID PLATE		RIVET HINGED		Alligator ready set		HanFlex		XP								
		BANT KALINLIĞI																		
Minimum Tambur çapı	4mm	5mm	6mm	7mm	8mm	9mm	10mm	11mm	12mm	13mm	14mm	15mm	16mm	17mm	18mm	19mm	20mm	22mm	24mm	30mm
75mm	RS125 (315N/mm)																			
100mm		RS187 (400N/mm)																		
150mm					375X (400N/mm)															
125mm						R2 (400N/mm)														
							R5 (800N/m)													
200mm									550 (500N/mm)											
250mm																				
300mm																				
300mm																				
350mm																				
350mm																				
400mm																				
500mm																				
500mm																				
500mm																				
700mm																				
850mm																				
1000mm																				
1000mm																				
1200mm																				
	4mm	5mm	6mm	7mm	8mm	9mm	10mm	11mm	12mm	13mm	14mm	15mm	16mm	17mm	18mm	19mm	20mm	22mm	24mm	30mm

Uyarı: Yukarıdaki tablo geçmiş deneyimlerimize göre hazırlanmıştır.
Bant hızı, ortam ve bant tipi yukarıdaki seçimleri değiştirebilir. Doğru seçim için lütfen temsilcimize danışınız.

Clipper®, Gator®, Unibar®, Tiebar®, Alligator®, Flexco®, markaları lisanslı Flexible Steel Lacing Company ürünüdür.



SÜRDÜRÜLEBİLİR MADENCİLİK ANLAYIŞI

MÜHENDİSLİK VE TEKNİK DANIŞMANLIK HİZMETİ

7/24 TEKNİK SERVİS

SATIŞ SONRASI DESTEK

PROFESYONEL SATIŞ EKİBİ



YERLİ MİLLİ ÜRETİMDE ÖNCÜ





GLOBAL MADENCİLİK
ÇÖZÜM ORTAĞINIZ

Labris A.Ş.



Sorularınız?



Teşekkürler



Biz Söz vermeyiz, İspatlarız

www.labris.com.tr

İletişim: +9(0) 312 499 32 55

Email: info@labris.com.tr

Adres: Taşpınar, Gölbaşı, Ankara